

Pumping

- Aggressive, explosive and toxic liquids
- Acids & lyes
- Hydrocarbons
- Heat transfer liquids
- Liquid gases
- Liquids Difficult-to-seal
- Ultrapure liquids

Applications

- Refineries
- Chemical and petrochemical industries
- Refrigeration and heat engineering
- Liquid gas plants
- Galvanic engineering
- Power stations
- Tank installations
- Pharmaceutical industries
- Fibers industries

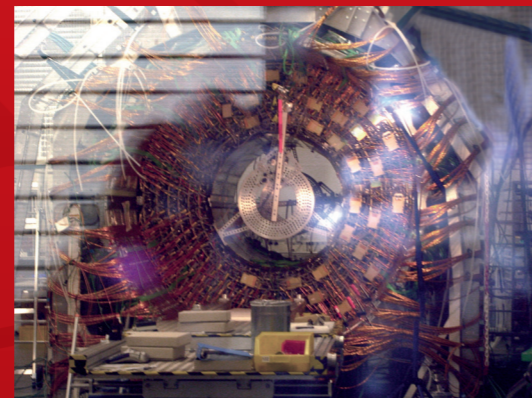
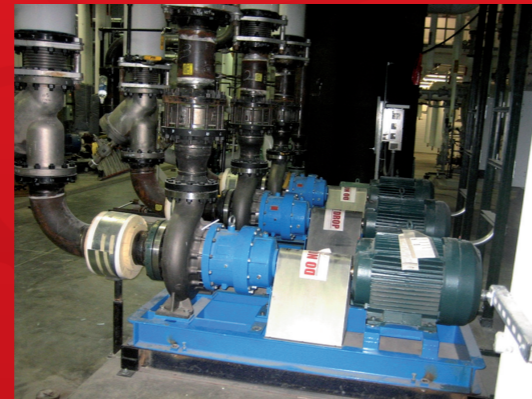
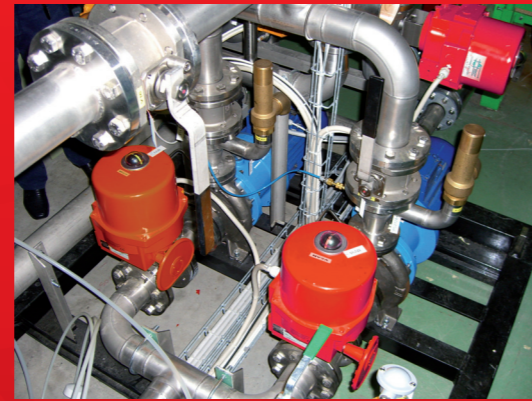

HEAVY DUTY HORIZONTAL, SEALLESS CENTRIFUGAL PUMP WITH PERMANENT MAGNET DRIVE SYSTEM, NO MECHANICAL SEAL ISO 2858 - DIN 24256



CN MAG-M

Manufactured by:



A unit of
Mischiatti
GROUP

M PUMPS s.r.l. - Via dell'Artigianato, 120
45015 Corbola (Ro) - Italy - www.mpumps.it
Tel. +39 0426 346304 - Fax +39 0426 349126

For more information please contact:



CN MAG-M Series

The separation of liquid chamber/atmosphere by means of an isolation shell is the best solution to pump aggressive, explosive and toxic liquids, hydrocarbons, heat transfer liquids and liquids difficult to seal. The hermetic sealless is the best solution for the chemical, pharmaceutical and petrochemical industry. A wide range of pumps covers the different performances.

General

M PUMPS CN MAG-M Magnetic drive pumps are sealless pumps. The static rear containment shell forms a closed system with hermetically sealed liquid end.

Applications

M PUMPS CN MAG-M Magnetic drive pumps are designed to improve people and plant safety. Especially when toxic, explosive or other dangerous liquids which react on contact with the atmosphere are handled. For all these services rear containment shell replaces double mechanical seals with external fluid reservoirs and all the required control devices. CN MAG-M pumps offer therefore exceptional benefits to the chemical, petrochemical and allied industries.

Maximum capacity up to 4000 mc/h, differential head up to 220m
 Temperature range from -185 °F (-120 °C) to +662°F (+350 °C) without external cooling. The maximum allowable working pressure 50bar for the standard version and 1500 bar for HP Version, higher pressure version available on request and temperature up to +842°F (+450°C).

Leakproof

CN MAG-M pumps have no glands, no seals no valves. Contrary to sealed centrifugal pumps, the hermetic construction of the CN MAG-M mag drive pump ensures a safe and leak free operation. Even under heavy-duty applications the pumps are extremely reliable.

Construction

M PUMPS CN MAG-M are a single stage volute casing pumps with closed impellers, back-pull-out design, with end suction and top discharge flange. Sturdy legs are provided as standard for foot mounting on the base plate. Capacity and outer dimensions according to DIN 24256/ISO 2858.

Advantages M PUMPS CN MAG-M mag drive centrifugal pumps

- Zero leakage (100% leak free)
- No mechanical seals or packed glands
- No external flushing systems
- Ensure a clean and safe operating environment, highly efficient
- Close couple and bare frame design
- No alignment required for closed couple version
- Increased Mean Time Between Maintenance

ATEX

M PUMPS CN MAG-M mag drive pumps can be supplied to meet the requirements of Directive 94/9/EC, with ATEX certification II -/2 G cbk II C Tx for installation in potentially explosive atmospheres.



The mag drive pumps have an extended choice of materials as well as a wide variety in models. With its 100% zero leakage mag drive coupling the M PUMPS mag drives are your problem solvers in fluids and chemicals transfer.

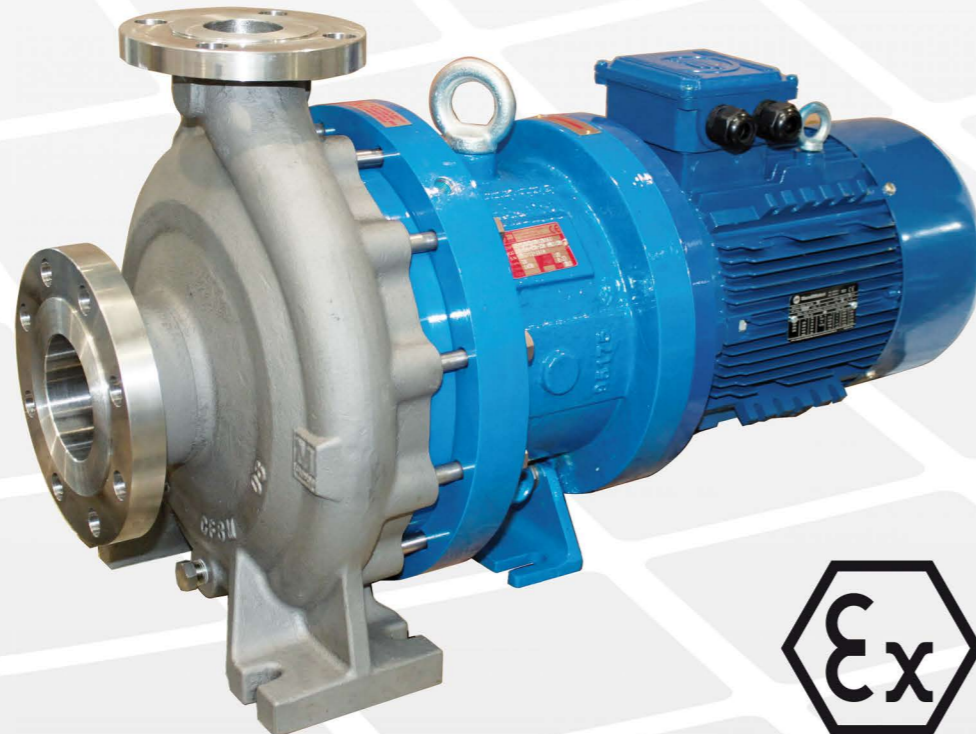

Performance curves

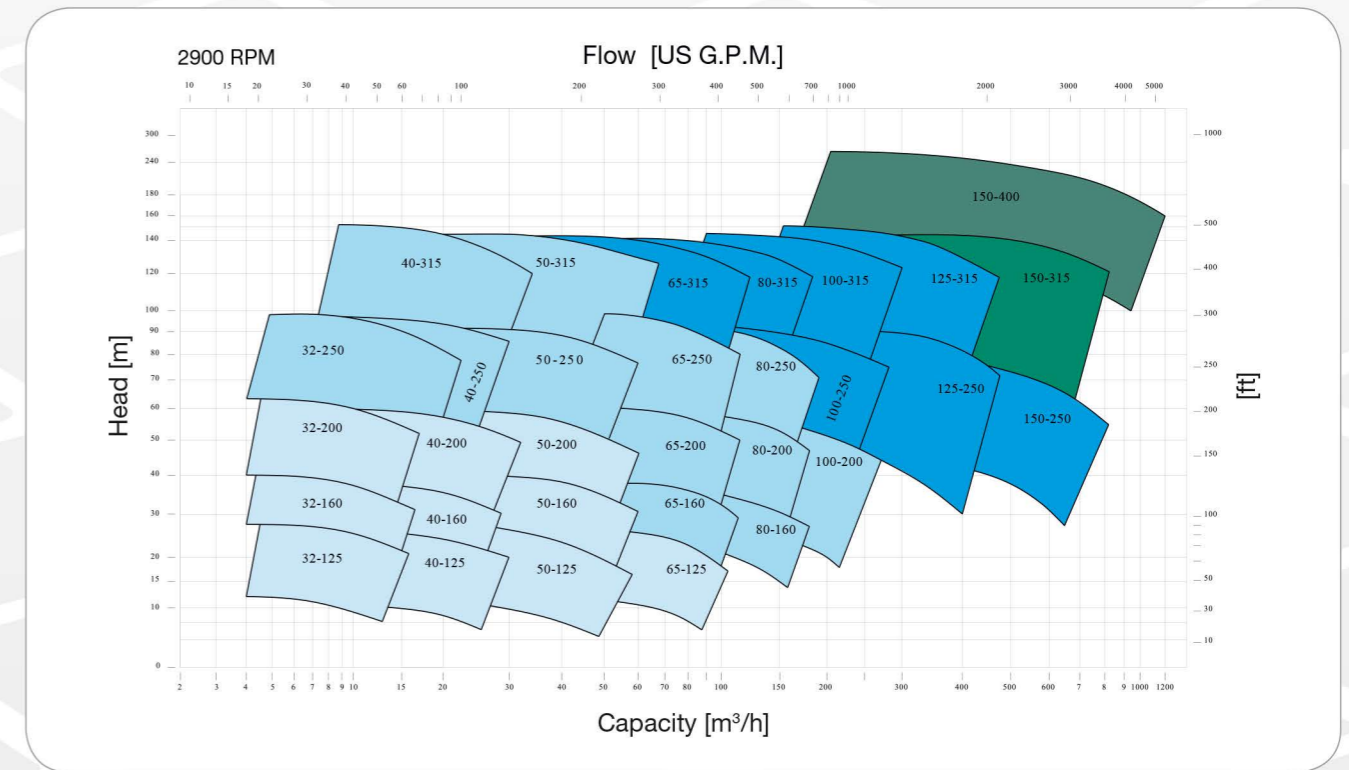
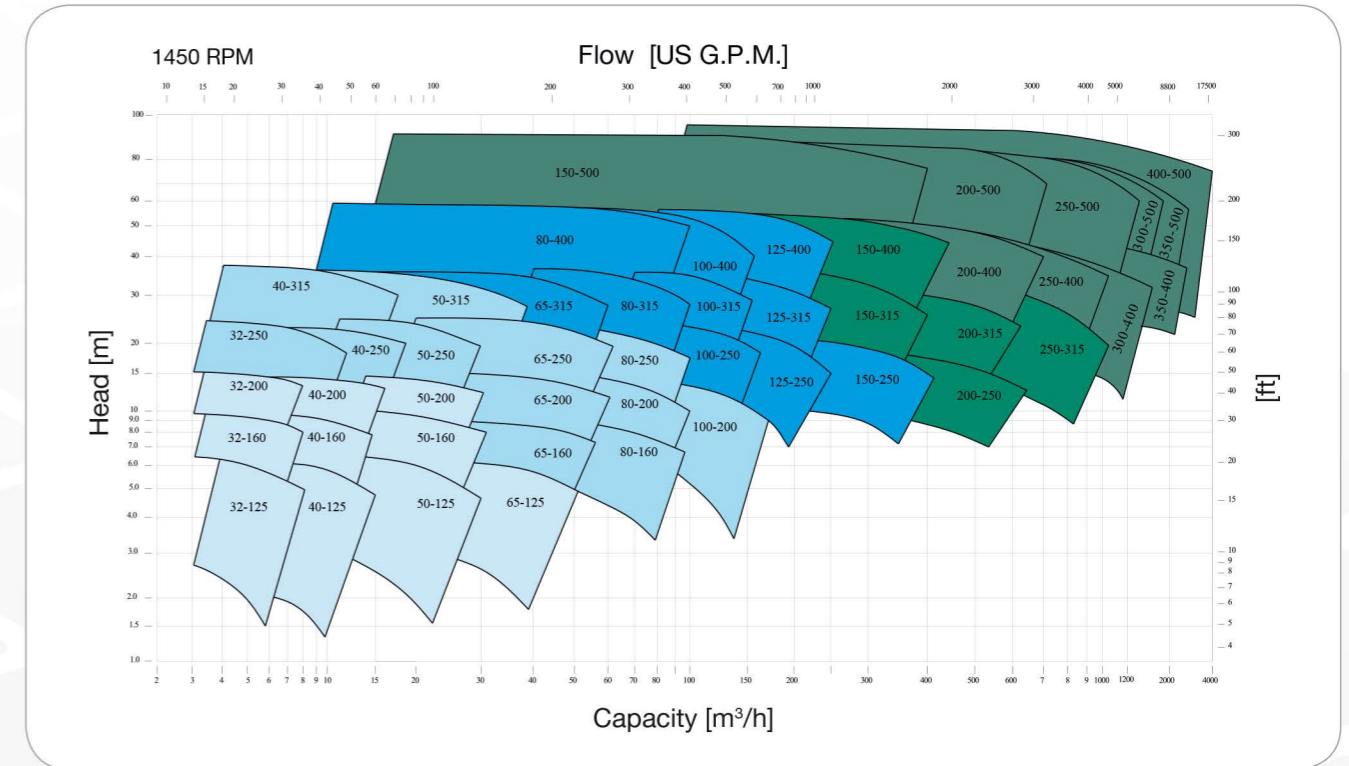

TEMPERATURES

Double slide bearings

The shaft is supported by two strong sleeve bearings. The stationary bearings are located centrally in the common bearing housing, which ensure the proper alignment for a true running. Standard material is pure alfa grade - Syntherized Silicon Carbide, highly resistant against corrosion and wear.

The Silicon Carbide parts are elastically mounted by tolerance rings, beared and designed for temperatures up to +662 °F (+350 °C) without heat exchanger.

Higher temperature on request.

Temperature control

Connections for resistant temperature detection elements, liquid and shell surface control are available as standard. Are also available on request monitoring devices for outer ball bearing.

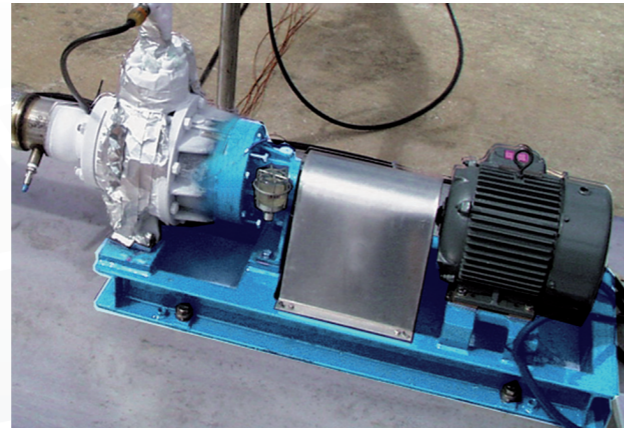

Temperature influences on pump casing pressure resistance

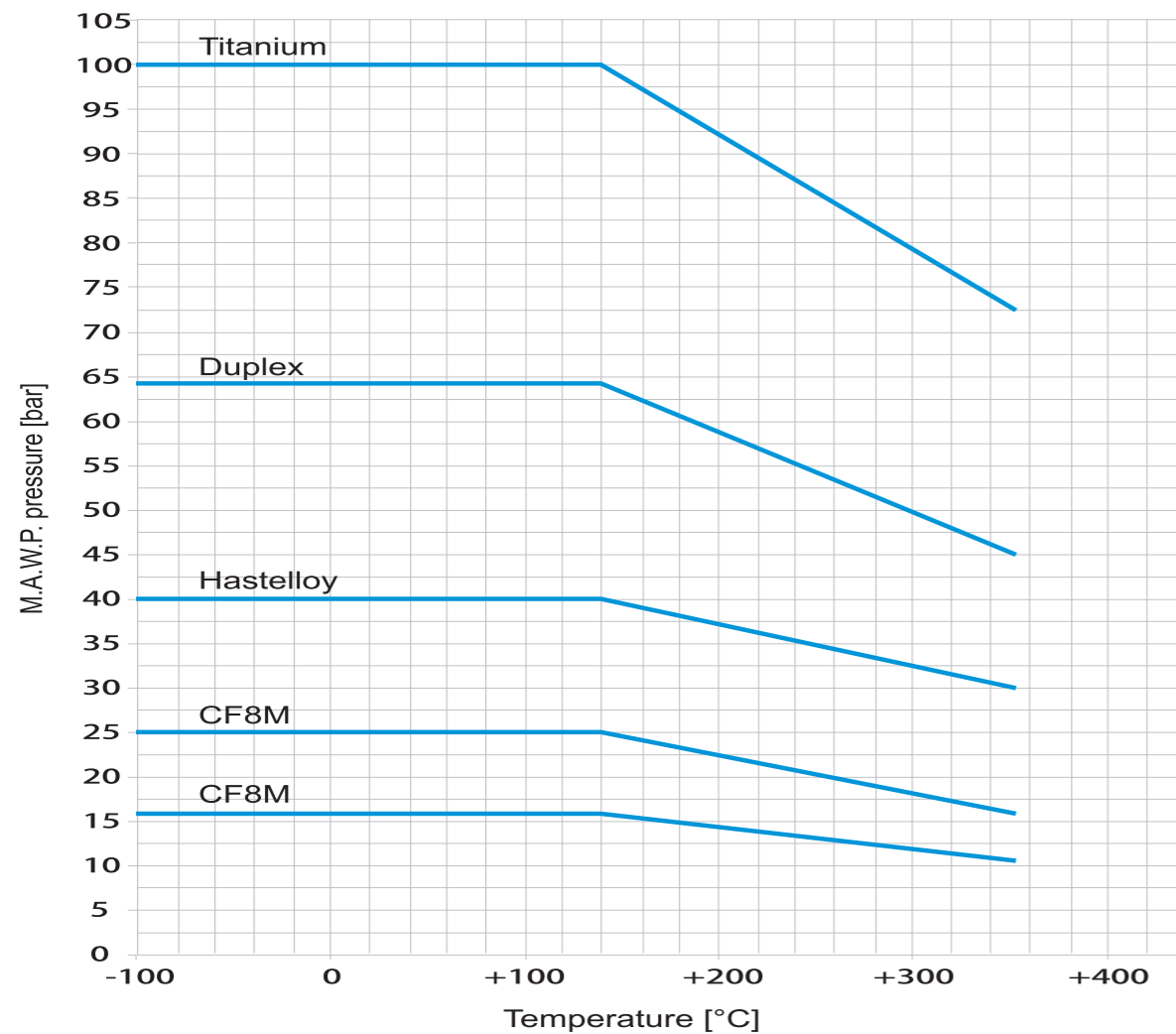

MAWP for M PUMPS CN MAG-M series ISO 2858 - DIN 24256

NPSH-Conditions

As the internal circulation from discharge to suction, doesn't rise temperature in the pumped liquid the handling of boiling liquids is possible without an increase of NPSH-required.

Balanced thrust loads

The thrust loads of the closed impellers are totally balanced by back vanes. Minimum residual forces that act in suction flange direction, are beared by strong silicon carbide, spring mounted, thrust bearings.

Rear containment shell protection

The clearances between the outer rotating magnets and the stationary shell and between the rotating magnet holder and bearing bracket prevent magnets from rubbing on the rear containment shell in case of ball bearing failure.

Internal circulation, pressurized containment shell area

When the pump is operating the heat generated in the containment shell and inner magnet area by eddy currents, is dissipated by an internal flow circulation from the discharge directly behind the impeller. The Pressure is increased by the rear impeller back vanes circulation, and come back to discharge.

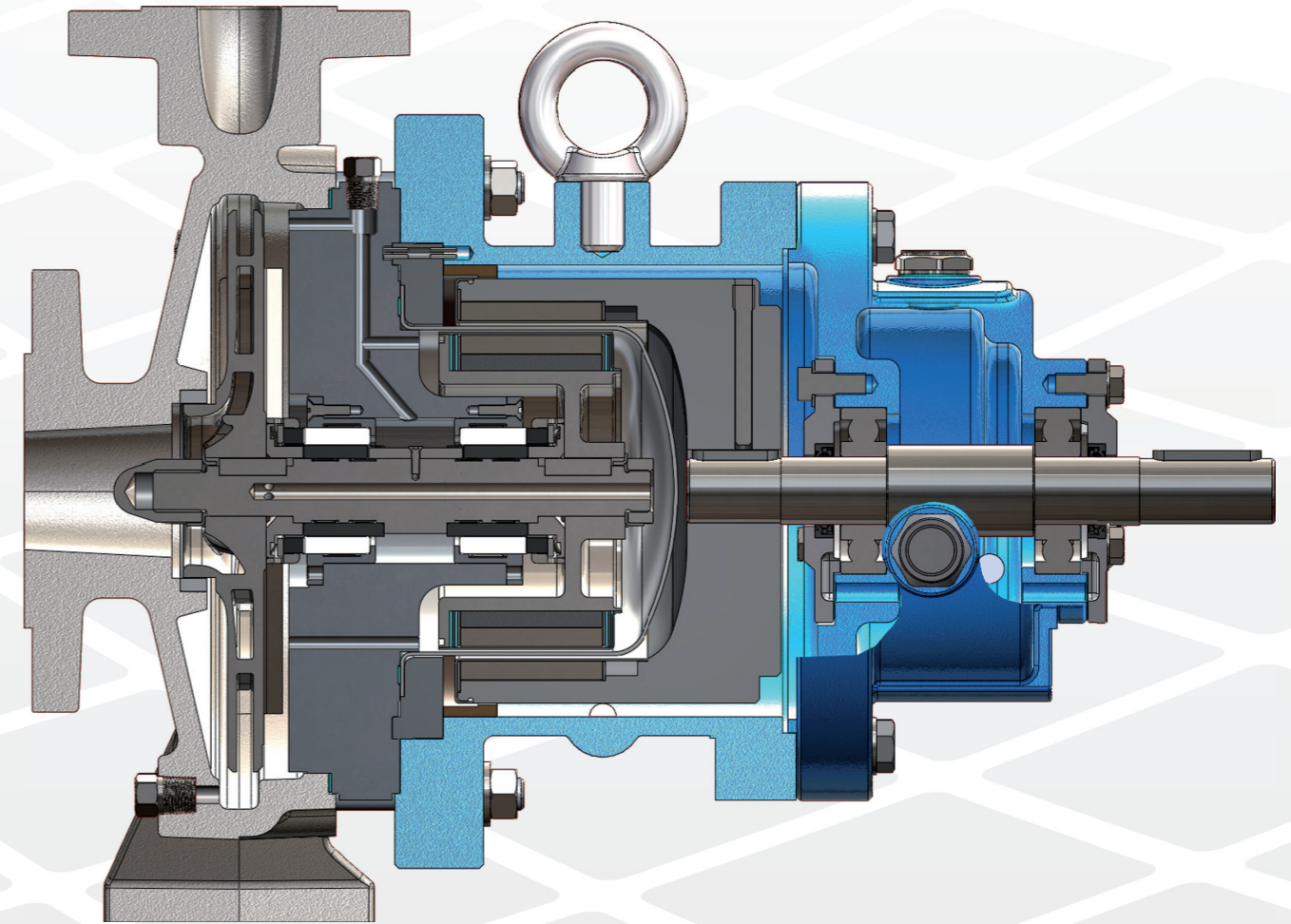

Outer ball bearings

The outer magnet shaft is fitted in generously dimensioned antifriction bearings. The bearings are L10 rated for an average life in excess of 5 years. The oil bath is protected against atmosphere by a lip seal (labyrinth oil seal on request).The oil level is controlled by a constant level oiler and additionally by a bull's eye sight glass.

Second & Third level containments

The double containment shell consists of two isolation shells placed one into the other. The gap between the two shells allows an effective monitoring via a pressure gauge or a vacuum system. Any alarm to interior or exterior shell will produce an alarm signal before any leakage occurs.

On request, a mechanical seal can be supplied in place of the lip seal. The mechanical seal separates the magnet area from the oil bath and atmosphere, and together with the closed bearing housing forms a third containment after the double containment shell.

PUMP DETAILS

Epoxy primer and polyacrylic enamel water-based painting for the best quality resistance linked to the environmental respect.

CF8M Pump Casing & Impeller High quality casting components.

Other materials:
 - Hastelloy® C276,
 - Incoloy® 825,
 - Duplex,
 - Titanium,
 - Other materials available on request.

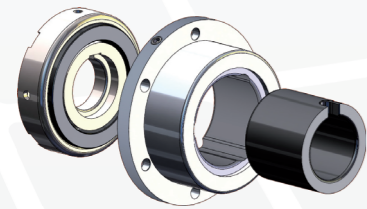

Field assembling of the product lubricated bearing arrangement does not require special tools.
 The Bearing materials available are of three different types to provide the best solution for each application: Silicon Carbide (SSIC), Tungsten Carbide (WC).
 Special configuration with PEEK composite compound for improved cavitation transitory resistance.
 The use of elastic rings reduces the sleeve bearing loads and the thrust bearing loads to a minimum, to guarantee many years of maintenance-free operation.

RWP QUICK CHANGE CARTRIDGE KIT to guarantee an easy and fast maintenance.

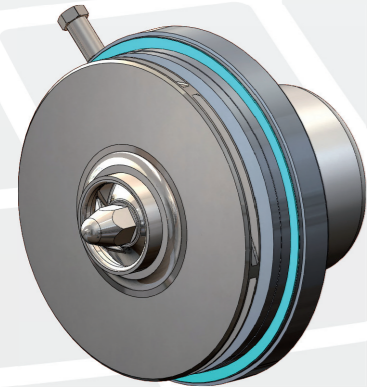

Closed impeller statically and dynamically balanced. The axial thrusts are balanced by back vanes.
 This allows the best balancing of axial thrusts without regards of suction pressure.

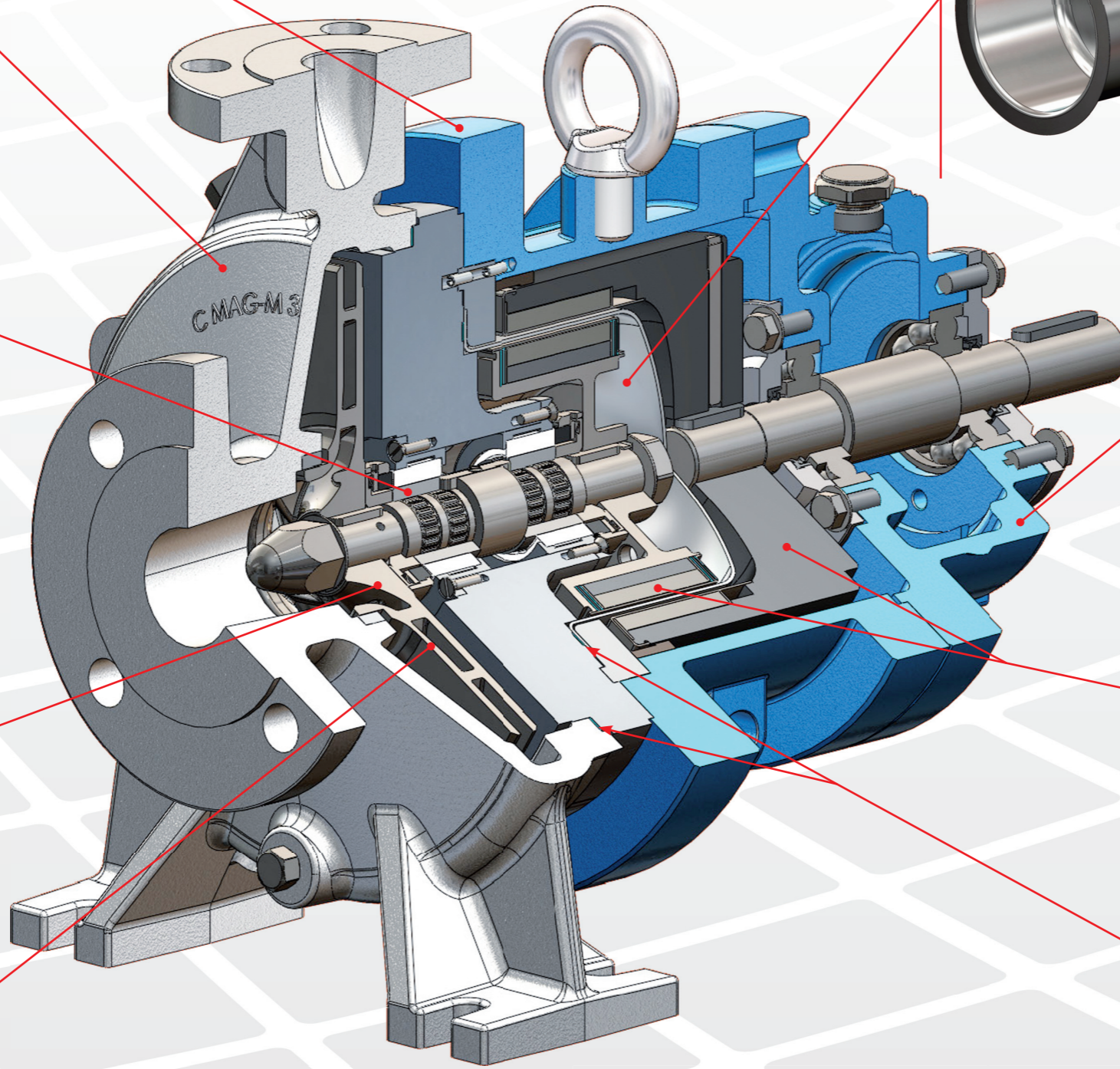

Rear shell is made of one single piece, no welding, ellipsoidal profile that has been studied to withstand higher pressures than the traditional one. Hastelloy® C276 is standard isolation shell material - providing a safe and efficient solution - system pressure max 16 bar. Hybrid rear casing technology available for energy saving configuration. Titanium Alloy is an upgrade when higher pressure ratings and increased efficiency are required. Double rear shell on request.

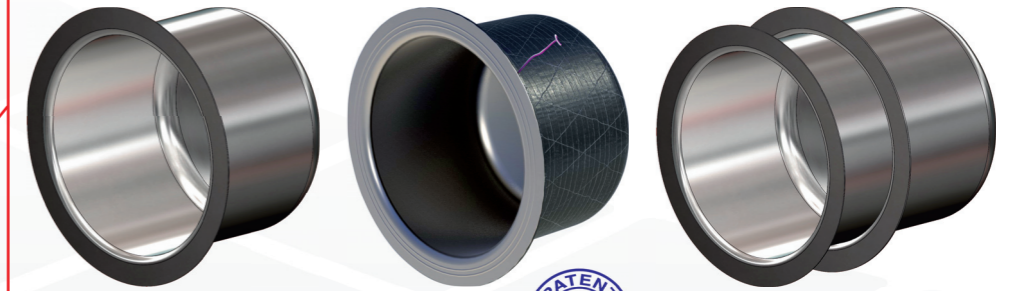

FILE NUMBER:
PD2010A000249



Close couple and bare shaft version

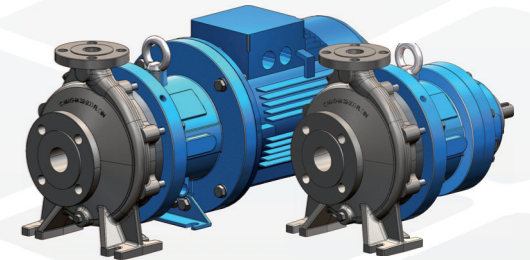

High power synchronous magnetic coupling designed by our Technical Office and with rare earth magnetic elements mechanically locked.
 The high performance magnets can operate at liquid temperature of up to 662 °F (350 °C) without external cooling. Installed power over 500 kW / 700 HP.

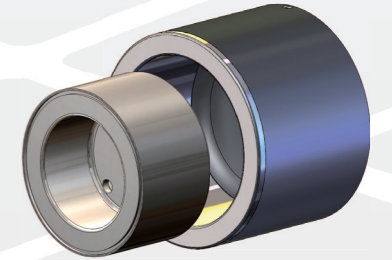

Sealing system with flat gaskets prevents from leaking in the atmosphere - different materials available:

- Asbestos free (standard)
- PTFE
- Graphoil
- GYLON®
- Spiral Wound
- Other on request